

COBALT RECOVERY FROM SPENT PORTABLE LITHIUM ACCUMULATORS AFTER THERMAL TREATMENT

M. Petrániková¹, A. Miškufová¹, T. Havlík¹, O. Forsén², A. Pehkonen²

¹ Technical University of Kosice, Faculty of Metallurgy, Department of Non-Ferrous Metals and Waste Treatment, Centre of Waste processing, Letna 9, 042 00 Kosice, Slovakia

² Aalto University, Faculty of Chemistry and Material Science, Department of Materials Science and Engineering, Corrosion and Material Chemistry, Vuorimiehentie 2, 020 15 Espoo, Finland

Received 03.03.2011

Accepted 15.06.2011

Corresponding author: M Petrániková, Tel.: +421 55 602 2400, Fax: +421 55 602 24 28, E-mail: martina.petranikova@tuke.sk, Technical University of Kosice, Faculty of Metallurgy, Department of Non-Ferrous Metals and Waste Treatment, Centre of Waste processing (www.censo.sk), Letna 9, 042 00 Kosice, Slovakia

Abstract

The possibilities of cobalt recovery from spent portable lithium accumulators were studied in this work. Incineration at 300, 500 and 700°C was realized in order to remove organic compounds. The highest loss on weight (around 25%) after incineration at 700°C was observed. Material after incineration was leached in 2M H₂SO₄ at 80°C without and with addition of H₂O₂. Leaching of treated samples with addition of H₂O₂ led to 100% of cobalt extraction. Thermal treatment of samples caused higher cobalt extraction at leaching without H₂O₂ addition in comparison to untreated samples. In general, positive effect of incineration on cobalt extraction was observed.

Keywords: accumulators, recycling, cobalt, recovery, incineration, leaching

1 Introduction

The necessary parts of our everyday life are spent portable batteries and accumulators. Accumulators are occurring in our cell-phones, laptops, beepers, mp3-players, etc.

At present, the majority of portable accumulators are on the base of nickel-cadmium, nickel-metal-hydride or lithium-ion and lithium polymer accumulators. Nowadays nickel-cadmium and nickel-metal-hydride accumulators are often replaced by lithium accumulators (LiA) in some areas due to absence of heavy metals and their better technical properties.

Production rate of portable lithium accumulators still increases and it tends to be higher. World LiA production reached 500 million units in 2000 and was expected to reach 4.6 billion in 2010 [1].

Although portable LiA have a long life-cycle, it happens that electric equipments which use LiA are replaced by new one earlier than they are functionless and so LiA become a waste too.

On the other hand portable LiA represent valuable secondary raw material and source of metals as cobalt, lithium, etc. LiA contain approximately 15-27% Co and 1.7-3.2% Li [2, 3].

Portable LiA consist of two thin electrode films: the anode is made from metallic copper and the cathode from metallic aluminium. The cathode film is covered by an active material (LiCoO₂, LiNiO₂ or LiMn₂O₄) as a fine powder, aggregated with a polymeric binder PVDF (polyvinylidenedefluoride) while the anode is covered by powdered graphitic carbon. In LiA, the

anodes and cathodes are made from materials that allow the migration of Li-ions through an electrolyte solution. The electrolyte is typically a mixture of organic carbonates such as ethylene carbonate or diethyl carbonate containing complexes of lithium ions [4].

In general spent portable LiA are recycled either by hydrometallurgical way or combined way in laboratory and industrial scale. Hydrometallurgical way mostly includes mechanical pre-treatment, leaching and extraction of particular metals [5,6]. Combined way usually includes mechanical and thermal pre-treatment, leaching and extraction. Thermal treatment is mainly used for organic compounds and graphite removal. Organic compounds are used as binder and cause problems during leaching and solid-liquid separation. Graphite causes a lower lithium extraction, because it acts as adsorbent for lithium [7, 8].

Lee and Ree [9] leached LiA after incineration at temperature 700 - 900°C. After thermal treatment cathode material was grinded in ball mill, dried and leached with nitric acid with and without addition of hydrogen peroxide. Extraction of cobalt was 40% and extraction of lithium was 75% in case without addition of hydrogen peroxide. By addition of hydrogen peroxide (1.7 vol.%) cobalt extraction increased to 85% and extraction of lithium was 85% at temperature 75°C.

Paulino et al. [7] calcined active material from LiA and active material from LiA mixed with KHSO_4 at 500°C. After thermal treatment material was leached with distilled water. It was found out, that calcination increased lithium recovery, because of carbon (adsorbent) removal. Cobalt was recovered either in form of $\text{Co}(\text{OH})_2$ using NaOH or $\text{CoSO}_4 \cdot 7\text{H}_2\text{O}$ using H_2SO_4 with addition of hydrogen peroxide.

Nan et al. [10] recovered metals from mixture of spent lithium-ion batteries and nickel metal hydride batteries. After incineration at temperature 580-630°C the mixture was leached with sulphuric acid with addition of hydrogen peroxide. About 90% of cobalt and nickel extraction was achieved using 3M H_2SO_4 with 3wt.% H_2O_2 at temperature 70°C after 5 hours.

Shin et al. [11] leached LiA with sulphuric acid and hydrogen peroxide. Incineration of LiA at temperature 900°C was applied in order to remove organic binders and graphite. It was found out, that incineration decreased cobalt extraction from 100% to 40%, because of presence aluminium foils, which covered lithium cobalt oxide particles when became molten at high temperature.

Li et al. [12] leached cathodic active material with citric acid and hydrogen peroxide after thermal treatment at temperature 700°C. About 100% of lithium and 90% of cobalt were extracted using 1.25 M citric acid with 1vol.% H_2O_2 at temperature 90°C.

Based on reported published works it is obvious that by thermal pretreatment carbon and organic binders are in general removed and extraction of Li is consequently improved but the effects of thermal treatment on cobalt extraction have not been thoroughly and expressly examined in most previous works. Thermal treatment was used only for pre-treatment of material without studying its influence on cobalt extraction.

In this work the possibilities of cobalt recovery from spent portable lithium accumulators after incineration were studied. The main aims were to observe the influence of thermal treatment on cobalt recovery and to determine optimal conditions for incineration and for following leaching of black mass from spent LiA.

2 Experimental

2.1 Material and methods

The lithium accumulators obtained from collection of spent portable batteries and accumulators at the Technical University of Košice were used for experiments. Collected lithium

accumulators were divided into four samples, whereby every sample contains the same amount and same type of accumulators. List and amount of particular accumulators used in every sample are given in **Table 1**. Total weight of one sample was 1027.19g.

Table 1 Accumulators used for experiment

Type	amount [pcs]	Type	amount [pcs]
SONY PSP 110	17	ERICSSON BST 30	1
FOR NOKIA 3310	2	ERICSSON BSL 11	1
NOKIA BLB 2	1	NOKIA BLC 2	3
SIEMENS X250	2	NOKIA BLD 3	1

LiA without dismantling were crushed using a hammer crusher SK 600. Samples for chemical analysis were obtained by quartation and following milling in vibration mill VM4. Chemical composition of sample after crushing is given in **Table 2**. Chemical composition of sample with particle size less than 1mm after sieving is given in **Table 3**. Chemical composition of samples before and after thermal treatment was carried out with atomic absorption spectrometer Varian AA-20+. Qualitative phase analysis has been done with X-ray diffractometer (Philips PW 3830, Cu-K α).

Table 2 Chemical composition of sample after crushing

Element	Co [%]	Cu [%]	Al [%]	Li [%]	Ni [%]	Fe [%]
Content [%]	10.81	9.15	10.68	1.815	2.34	0.385

Table 3 Chemical composition of sample after sieving (-1 + 0 mm)

Element	Co [%]	Cu [%]	Al [%]	Li [%]	Ni [%]	Fe [%]
Content [%]	18.2	3.65	1.77	3.2	2.78	0.34

Samples of crushed LiA were introduced to grain size analysis by dry sieving method. For this purpose sieves with openings 9, 4, 1, 0.63, 0.4 and 0,09mm were used. Histogram of sample granularity is shown in **Figure 1**.

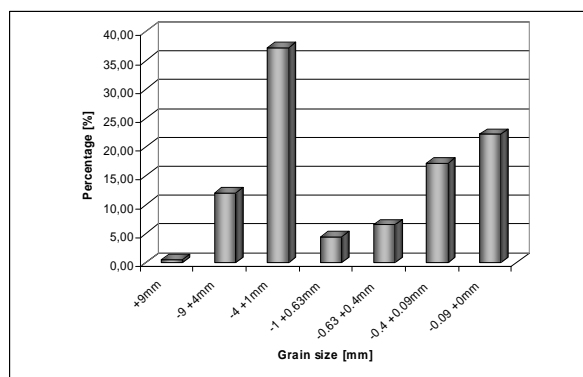

Fig.1 Histogram of sample granularity.

According to grain size analysis results and chemical composition of particular fractions, fraction over 1mm was removed by sieving, because this fraction contains majority of copper and aluminium foils and plastics. Fraction under 1mm were used for experiments. Distribution of particular metals in both fractions (+ 1mm, -1+0 mm) is shown in **Figure 2**.

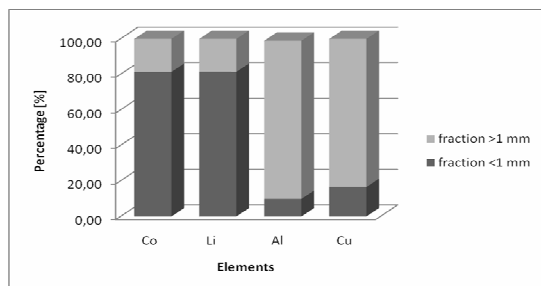

Fig.2 Content distribution of metals after sieving

2.2 Thermal treatment - incineration

Thermal treatment was carried out in furnace SCANDIA OVEN TC 8000 (**Figure 3**). Samples were charged into the sample holder and inserted into the furnace, which was heated up at required temperature. The air supply to the sample holder was provided by compressor Masterflex GWB. Off-gas was taken away through copper tube and cleaned by washing system consisted of five washing bottles. First of them was empty (safety reasons), the second one contained solution of 0.5M NaOH and the fourth one contained 0.5M H₂SO₄. Distilled water was placed into the third and the fifth bottle.

Experiments were carried out at the temperatures 300°C, 500°C and 700°C for 60 minutes. Amount of sample was 25g. Loss on weight and chemical composition were determined after thermal treatment. XRD measurements and SEM observations of treated and untreated sample were also realized.

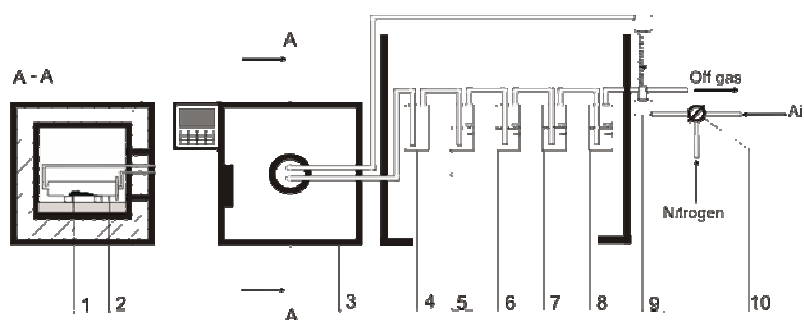

Fig.3 Scheme of apparatus for incineration.

1-sample, 2-sample holder, 3-furnace, 4-empty vessel, 5-NaOH solution, 6,8- distilled water, 7-H₂SO₄ solution, 9-flowmeter, 10-tap

2.3 Leaching experiments

Leaching was carried out in glass vessel inserted in water bath (**Figure 4**). Required temperature was adjusted using thermostat LAUDA A100. For stirring the plastic propeller was used. As leaching agent the 2M sulphuric acid was used and as reducing agent 30% hydrogen peroxide. Amount of hydrogen peroxide was 0vol.% or 15vol.%. Solid to liquid ratio was always 1:80. Experiments were carried out at temperature 80°C for 60 minutes. For leaching experiments the samples without thermal treatment and after incineration were used. Amount of sample was 5g. Liquid samples were analyzed by AAS (Perkin Elmer 272). Extraction values were corrected in compliance with loss of leaching solution due to sample off-take and solution evaporation.

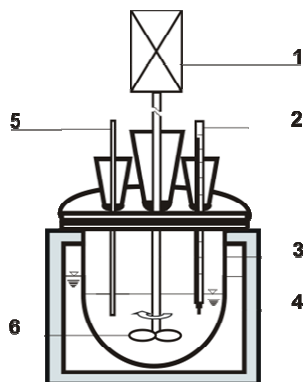

Fig.4 Leaching apparatus.

1-stirrer engine, 2-thermometer, 3-leaching reactor, 4-water thermostat, 5-sampler, 6-propeller

3 Results and discussion

3.1 Thermal treatment

Loss on weight

Loss on weight of samples after incineration at different temperatures is shown in **Figure 5**. At temperature 300°C the mass sample was reduced only about 10%. According to available data for average organics and carbon content in portable Li-accumulators, this temperature is probably not sufficient for burning out the organics and carbon. With increasing temperature the loss of weight increased and the highest value was observed at temperature 700°C after 60 minutes of incineration.

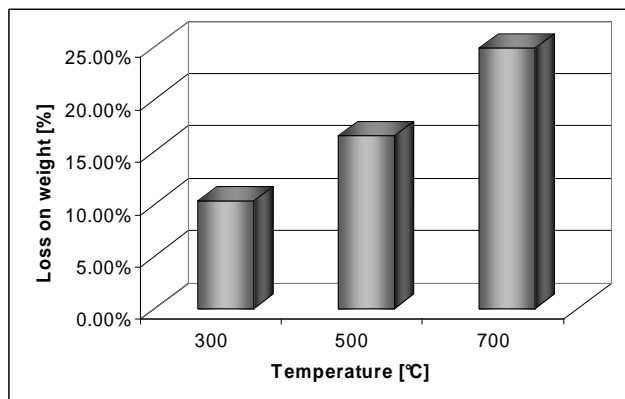

Fig.5 Loss on weight after incineration.

XRD (X-ray diffraction analysis)

XRD analysis shows that cobalt in the sample before thermal treatment is present in the form of LiCoO_2 (**Figure 6a**). According to XDR diffraction patterns of the sample after incineration at 300°C (**Figure 6b**) it is obvious that temperature 300°C is not sufficient for removal of carbon and LiCoO_2 decomposition. Partial decomposition of LiCoO_2 occurred at temperature 500°C and 700°C (**Figure 6c,d**). Cobalt is also present in the form of CoO and Co_3O_4 in samples after treatment at 700°C (**Figure 6d**). Partial decomposition of LiCoO_2 to Co_3O_4 occurred at

temperature 500°C (Figure 6c). As diffraction patterns show, carbon is still present in samples even though incineration at relatively high temperature was carried out.

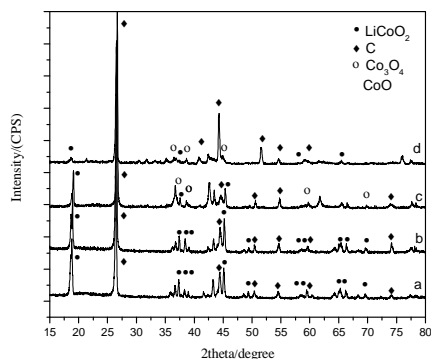

Fig.6 X-ray diffraction of untreated (fraction -1+0mm) and treated samples.

SEM (scanning electron microscopy)

SEM micrographs of untreated and treated samples are shown in **Figure 7**. There are some clusters of black mass visible in Figure 7a and 7b. Probably it is a consequence of organic compounds presence, because organic compounds used in LiA as binders join the particles of black mass. Samples, which were treated at higher temperatures, were more liberated even though there are some small clusters in sample after incineration at 700°C.

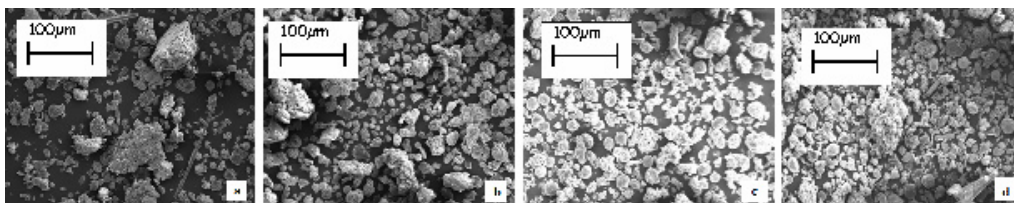

Fig.7 SEM micrographs of samples: a, untreated sample; b, sample after incineration at 300°C; c, sample after incineration at 500°C; d, sample after incineration at 700°C.

3.2 Leaching

Kinetic curves of cobalt extraction are shown in Figure 7-10. Kinetic curves of cobalt extraction in 2M sulphuric acid at 40°C and 80°C with and without addition of hydrogen peroxide are shown in **Figure 8**. According to these results temperature 80°C was chosen for next experiments. Despite extractions of cobalt after 2 hours at both temperatures are very similar, higher temperature enables to reach higher efficiency in general. As follows from results, the addition of hydrogen peroxide significantly increases cobalt extraction.

Untreated and incinerated samples were leached in 2M H₂SO₄ at 80°C without addition of hydrogen peroxide. Kinetic curves of cobalt extraction under these conditions are shown in **Figure 9**. As follows from results cobalt extraction of samples after incineration at 500°C and 700°C is much higher than cobalt extraction of samples after incineration at 300°C and untreated samples at the same conditions. This is due to the fact that Co²⁺ can be readily dissolved then Co³⁺ [5]. During the incineration partial decomposition of LiCoO₂ to Co₃O₄ occurred at temperature

500°C and partial decomposition of LiCoO_2 to CoO and Co_3O_4 occurred at temperature 700°C (Figure 6). As follows from kinetic curves in Figure 9, cobalt extraction of sample incinerated at 300°C is very similar to cobalt extraction of untreated samples and this is due to fact that temperature 300°C is not sufficient for LiCoO_2 decomposition. The highest Co extraction value about 80% was achieved with sample incinerated at 700°C. Important fact is that cobalt extraction is doubled after 60 minutes of leaching at given conditions in compare with cobalt extraction from untreated samples and samples after incineration at 300°C.

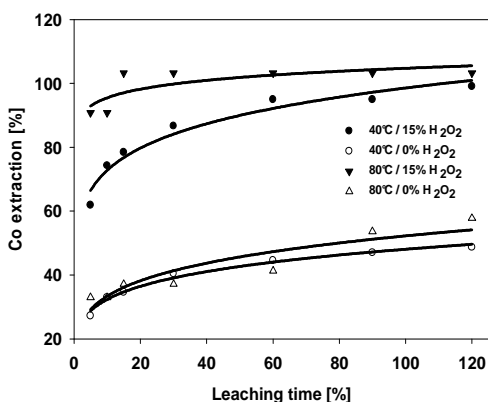

Fig.8 Kinetic curves of cobalt extraction in 2M sulphuric acid with and without addition of hydrogen peroxide at 40°C and 80°C (untreated sample).

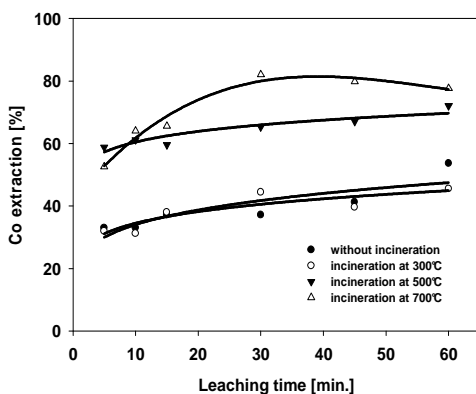
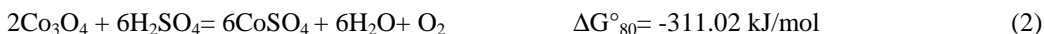

Fig.9 Kinetic curves of cobalt extraction in 2M sulphuric acid after incineration without addition of hydrogen peroxide at 80°C.

Values of Gibbs Free energy of reactions of cobalt oxides with sulphuric acid are following:



These values signify that both of reactions are probable from thermodynamic point of view at given conditions and reactions tend to proceed along with creation of reaction products, but reaction (2) is more favorable.

Samples before and after incineration at particular temperatures were leached in 2M H₂SO₄ at 80°C with 15vol.% addition of hydrogen peroxide. Kinetic curves of cobalt extraction in 2M sulphuric acid with addition of hydrogen peroxide at 80°C are shown in Figure 10. The addition of hydrogen peroxide led to full extraction of cobalt in all cases. Hydrogen peroxide is used as reduction agent and it causes the reduction of Co³⁺ to Co²⁺.

As follows from kinetic curves, entire amount of cobalt was extracted from samples after incineration at 500°C and 700°C in first five minutes. Whole amount of cobalt was extracted from untreated samples and samples after incineration at 300°C too, but to reach total extraction termed about 40 minutes.

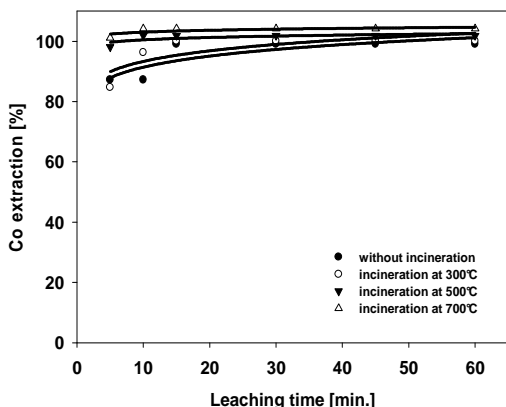
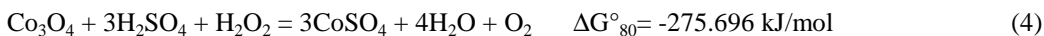

Fig.10 Kinetic curves of cobalt extraction in 2M sulphuric acid with addition of hydrogen peroxide at 80°C.

The values of Gibbs Free energy of chemical reactions of CoO and Co₃O₄ with sulphuric acid and hydrogen peroxide are following:



4 Conclusion

Possibilities of cobalt recovery from black mass from spent lithium accumulators were studied in this work. Spent portable lithium accumulators were crushed and sieved. Fraction less than 1mm, which contained majority of black - active mass, was used for experiments. The graphite is part of electrode material, but it effects as adsorbent for lithium in leaching process. Organic compounds are used as binders and solvents. They are hydrophobic and cause difficulties in leaching and solid-liquid separation processes. An incineration at different temperatures was chosen for thermal pre-treatment of black mass. Samples of black mass were incinerated at 300°C, 500°C and 700°C for 60 minutes. From results follows that temperature 300°C, when loss on weight was only 10%, is insufficient for burning out of carbon present in LiA. With increasing temperature the loss of weight increased and its highest value about 25% was observed at temperature 700°C after 60 minutes of incineration. Partial decomposition of lithium cobalt oxide to Co₃O₄ at 500°C and partial decomposition of lithium cobalt oxide to Co₃O₄ and CoO at 700°C was confirmed by XRD analysis. Analysis also confirmed that even temperature 700°C is insufficient for graphite removal.

Untreated samples and samples after incineration were leached in 2M H₂SO₄ at 80°C with and without addition of hydrogen peroxide.

When untreated samples and treated samples were leached without addition of hydrogen peroxide, higher cobalt extraction was achieved only from samples after incineration at 500°C and 700°C. Cobalt extraction of untreated samples and samples after incineration at 300°C was about 45% and it is due to that decomposition of lithium cobalt oxide did not occur and this compound is not as leachable as its oxidic products after decomposition. The highest cobalt recovery (80%) was achieved from sample after incineration at 700°C.

When addition of hydrogen peroxide was used, total amount of cobalt was extracted from all samples. The entire amount was extracted from samples after incineration at 500°C and 700°C in the first five minutes whereas to achieve this state in case of untreated samples and samples after incineration at 300°C termed approximately 45 minutes.

In general from results follows that thermal treatment has positive effect on cobalt extraction. This finding is very important for determination of real influence of thermal treatment on cobalt recovery, because till now it has not been defined.

Seeing that total cobalt extraction was reached only with using hydrogen peroxide, it is necessary further to study the influence of temperature of incineration on black mass and Co extraction in general. Finally, it is necessary to define the optimum conditions for achieving a maximum cobalt extraction.

To confirm the total influence of incineration on black mass and cobalt extraction it is necessary to study its effects on the other elements and metals present in this material, mainly lithium, which is becoming a valuable part of this secondary raw material too.

Acknowledgements

This work was supported by Ministry of Education of the Slovak republic under Grant MS SR 1/0123/11. This work was also realized with financial support of project No. APVV-20-013405 and project of grant agency VEGA of Slovak Ministry of education 1/0087/08. This contribution is also the result of the project implementation Research excellence centre on earth sources, extraction and treatment supported by the Research & Development Operational Program funded by the ERDF, ITMS number: 26220120017.

References

- [1] M.B.J.G. Freitas, E.M. Garsia: Journal of Power Sources, Vol. 171, 2007, p. 953-959.
- [2] I. Vassura, L. Morselli, E. Bernardi, F. Passarini: Waste Management, Vol. 29, 2009, p. 2332-2335.
- [3] A. Miškuřová, T. Havlík, M. Petrániková, D. Oráč: Perspectives of nickel and cobalt recovery from spent batteries in Slovakia, In.: Recycling of spent portable batteries and accumulators, Sklené Teplice, Equilibria s.r.o., 2009, p. 120-132, (in Slovak).
- [4] L. Li, J. Ge, R. Chen, F. Wu, S. Chen, X. Zhang: Waste Management, Vol. 30, 2010, p. 2615-2621.
- [5] M. Petrániková, A. Miškuřová, T. Havlík, D. Oráč: Present status in recycling of lithium containing batteries, In.: Recycling of spent portable batteries and accumulators, Sklené Teplice, Equilibria s.r.o., 2009, p. 143-154, (in Slovak).
- [6] R. Wang, Y. Lin, S. Wu: Hydrometallurgy, Vol. 99, 2009, p.194-201.
- [7] J. Paulino, N. Busnardo, J. Afonso: Journal of Hazardous Materials, Vol. 150, 2008, p. 843-849.

-
- [8] Y. Kim, M. Matsuda, A. Shibayama, T. Fujita: Resources processing, Vol. 51, 2003, No.1, p. 3-7.
- [9] CH. Lee, K.I. Rhee: Hydrometallurgy, Vol. 68, 2003, p. 5-10.
- [10] J. Nan, D. Han, M. Yang, M. Cui, X. Hou: Hydrometallurgy, Vol. 84, 2006, p. 75-80.
- [11] S. Shin, N. Kim, J. Sohn, D. Yang, Y. Kim: Hydrometallurgy, Vol. 79, 2005, p. 172-181.
- [12] L. Li, J. Ge, F. Wu, R. Chen, S. Chen, B. Wu: Journal of Hazardous Materials, Vol. 176, 2010, p. 288–293.